

Eclipse ThermAir

Burners

Model TA0500

Version 2

Parameter		Specification		
		Packaged Blower Size		
Maximum Input, BTU/hr (kW)^{1 2} <i>(To maintain 15% air with the standard air orifice and standard combustion air blower.)</i>	Chamber Pressure "w.c. (mbar)	60 Hz	50 Hz	
		-1.0 (-2,5)	5,277,000 (1547)	5,315,000 (1556)
		0.0 (0,0)	5,000,000 (1467)	5,074,000 (1486)
		1.0 (2,5)	4,773,000 (1400)	4,821,000 (1412)
Minimum Input, BTU/hr (kW)		167,000 (49,0)		
Main Gas Inlet Pressure, "w.c. (mbar)³ <i>Fuel pressure in gas inlet (Tap B)</i>		8.7 (21)		
High Fire Flame Length, inches (mm) <i>Measured from outlet end of combustor</i>	Natural Gas	97 (2464)		
	Propane	107 (2718)		
	Butane	112 (2845)		
Maximum Application Temperature, °F (°C) <i>Note: For higher temperatures contact Eclipse.</i>	Alloy Tube	1500 (820)		
	Block and Holder	1900 (1040)		
Flame Detection		UV Scanner		
Fuel⁴ <i>For any other mixed gases, contact Eclipse.</i>		Natural gas, propane, or butane		
Blower Motor Power		10" w.c. @ 55000 scfh, 3 hp		
Weight, lbs (kg)⁵	With Alloy Combustor	492 (223)		
	Without Alloy Combustor	251 (114)		
	Block and Holder with Blower	640 (290)		
	Block and Holder without Blower	397 (180)		
Approvals		 AN30		

- Maximum inputs are given for the standard combustion air blower without an air filter.
- Blower motor service factors greater than 1.0 may be required when firing into negative chamber pressure applications. For specific application questions, contact Eclipse.
- For proper performance, this pressure must be kept constant across the burner operating range.
- See Design Guide 114 for more information about typical fuel composition and properties.
- All weights are approximate.
 - All information based on laboratory testing in neutral (0.0" w.c.) chamber with standard combustion design. Different chamber conditions and/or combustor design will affect the data.
 - All inputs are based upon gross calorific values and standard conditions: 1 atmosphere, 70°F (21°C).
 - Eclipse reserves the right to change the construction and/or configuration of our products at any time without being obliged to adjust earlier supplies accordingly.

Performance Graphs

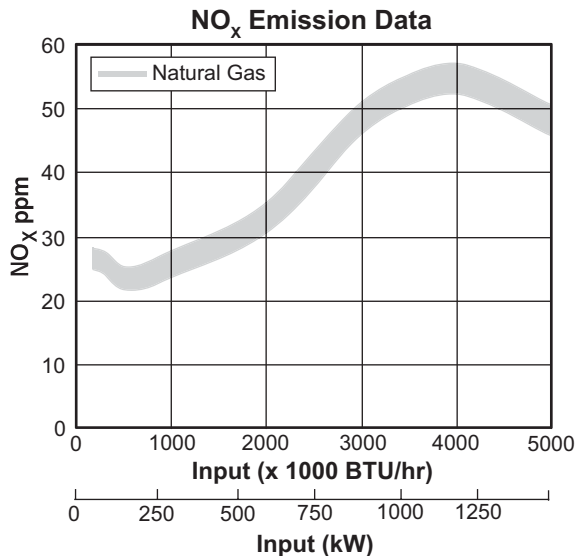
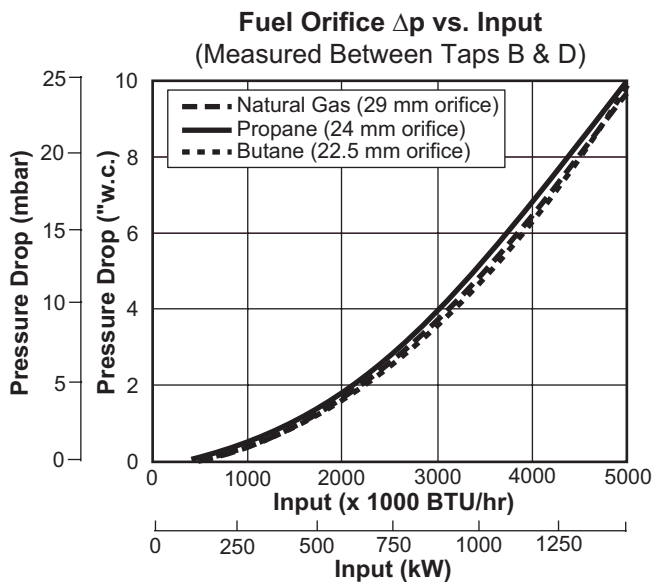
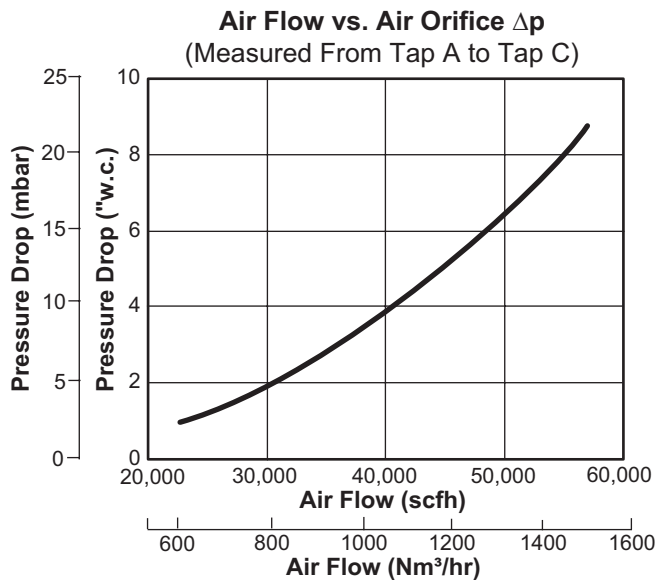
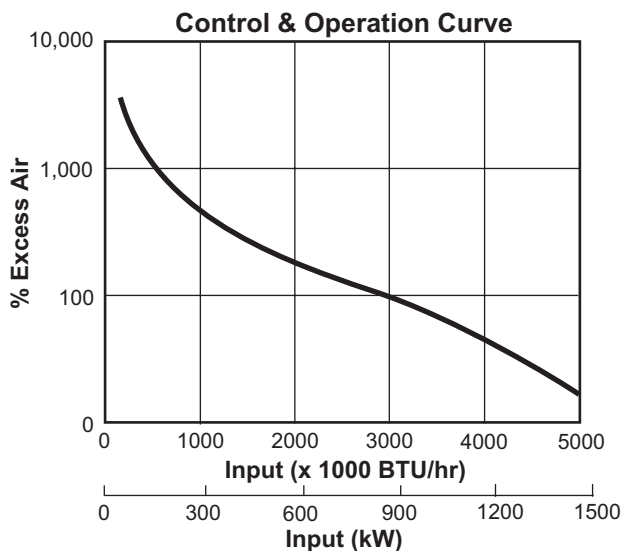

NO_x emission data is given for:

- Ambient combustion air ~70°F (20°C)
- Minimal process air velocity
- ppm volume dry at 3% O₂
- Neutral chamber pressure

Emissions are influenced by:

- Chamber conditions
- Fuel type
- Firing rate
- Ratio regulator adjustment
- Combustion air temperature

CO emission is largely influenced by chamber conditions. Contact your local Eclipse representative for an estimate of CO emission on your application.

Dimensions mm (inches)

Blower	EE	FF	GG	HH
60 Hz (10" wc)	850 (33.5)	936 (36.9)	613 (24.1)	593 (23.3)
50 Hz (10" wc)	869 (34.2)	995 (37.6)	647 (25.5)	627 (24.7)

Packaged Blower

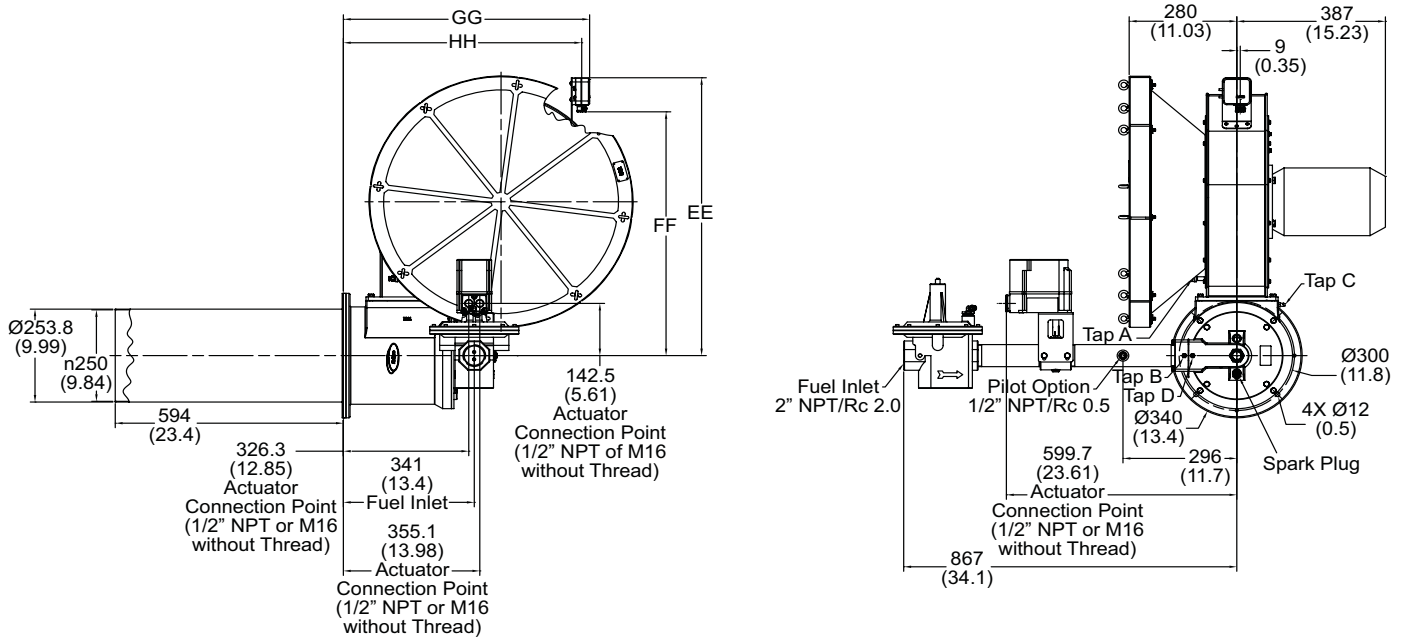

Remote Blower (shown with Block and Holder)

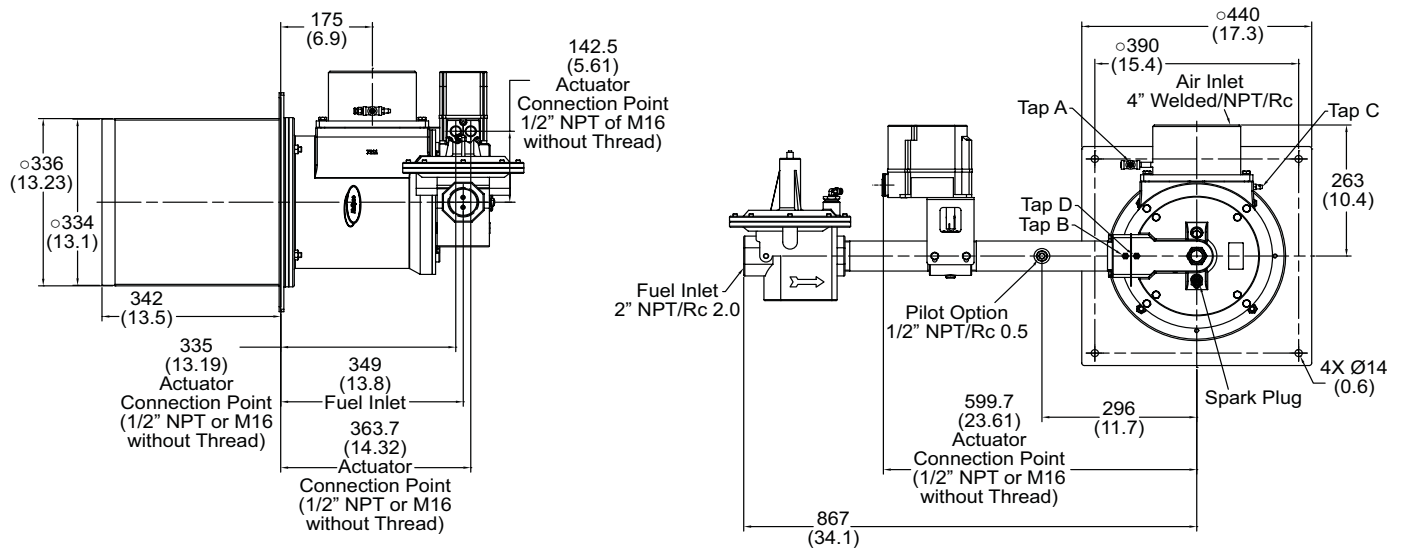

Piping

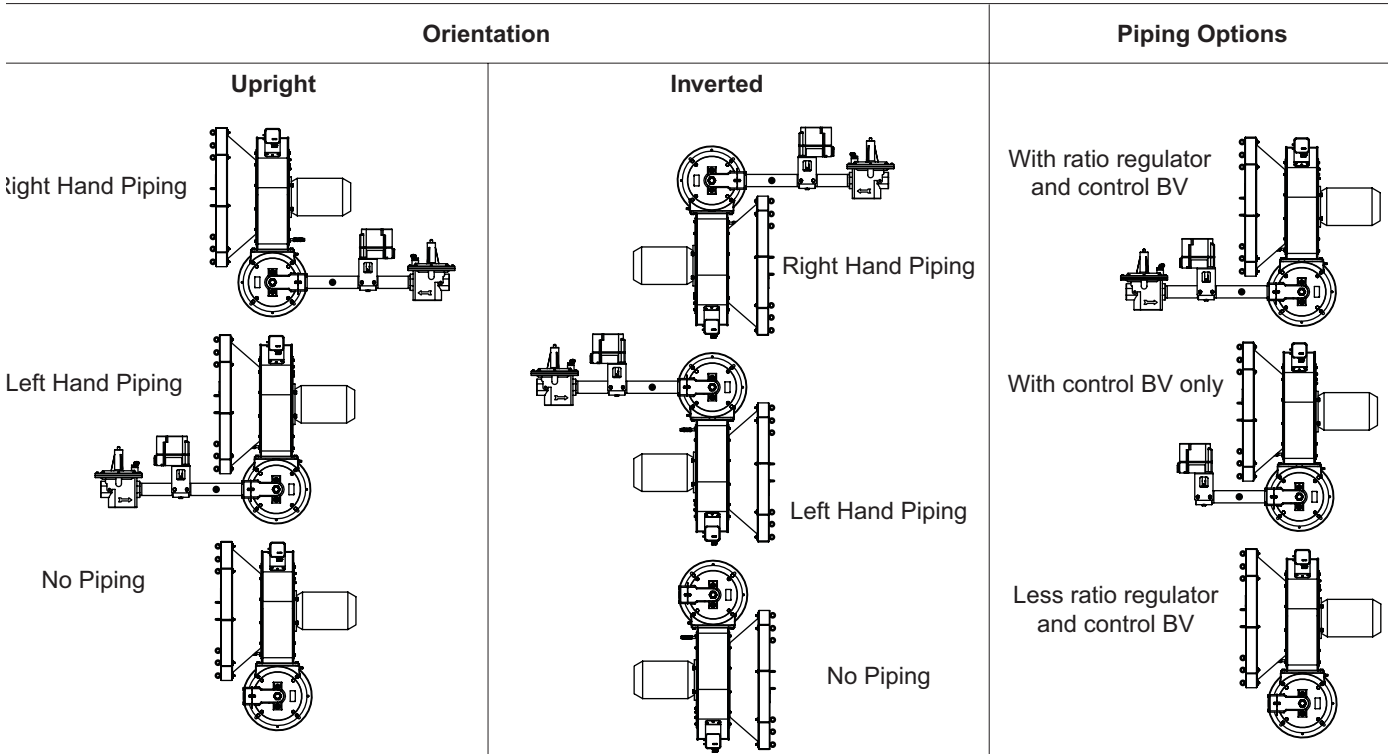



Offered By:

Power Equipment Company
2011 Williamsburg Road
Richmond, Virginia 23231
Phone (804) 236-3800
Fax (804) 236-3882

www.peconet.com